

Road 19—RCB & Wingwalls
Bid Open: April 25, 2024 at 10:30 AM

Company Name _____

Contact Name _____

Email Address _____

Street Address _____

City, State, Zip Code _____

Phone _____

Addendums can potentially be issued as late as the day before the bid opening. Completing and returning this form ensures you will be directly informed of any addendums.

Email or Fax completed form to Putnam County Engineer's Office:

michael.lenhart@putnamcountyohio.gov

Fax: (419) 523-6014

OFFICE OF THE COUNTY ENGINEER

PROPOSAL

**TO THE BOARD OF COUNTY COMMISSIONERS
COUNTY OF PUTNAM**

For: Road 19—RCB & Wingwalls

Bidder's Name: _____

Street Address: _____

P.O. Box: _____

City, State, Zip: _____

Date of Letting: April 25, 2024

Place of Letting: Putnam County Board of Commissioners

245 E. Main Street

Ottawa, Ohio 45875

Completion Date: July 31, 2024

Prepared By:
Putnam County Engineer
245 E. Main Street, Ste. 205
Ottawa, OH 45875

Michael L. Lenhart, P.E., P.S.

BID DOCUMENTS

Table of Contents

<u>DESCRIPTION</u>	<u>PAGE</u>
Table of Contents	ii.
Advertisement; Notice to Contractors	iv.
Introduction	v.
I. Instructions to Bidders	1
1. Submission of Bid	1
2. Standard Specifications & Terms	1
3. Form of Bid	2
4. Bidder Qualifications	2
5. Examination of Bid Documents & Site of Work	2
6. Bid Guarantee	2
7. Factors for Acceptance or Rejection of Bids	3
8. Withdrawal of Bids	3
9. Prevailing Wage Rates	3
10. Other Costs & Requirements	3
II. Supplemental Contract Provisions	5
1. Award Requirements of Successful Bidder/Contractor	5
2. Other Contractor Duties	6
3. Discrimination Prohibited	6
4. Inspection	7
5. Changes in Quantity of Work	8
6. Significant Changes in Character of the Work	8
7. No Waiver Rights	9
8. Damages for Late Completion; Extensions of Time	10
9. Night, Sunday & Holiday Work	10
10. Partial Payments	10
III. Scope of Work	12
1. Generally	12
2. Schedule of Performance	12
IV. Plans and Specifications	13
1. Generally	13
2. "Or Equal"	13
3. List of Plans and Specifications	13
V. Prevailing Wage Rate Schedules	14

VI. Proposal Forms (to be completed by bidder)	16
1. Bidder Qualifications	16
2. Equal Employment Opportunity Compliance Certificate	19
3. Declaration: Personal Property Tax Delinquency	21
4. Certificate: Unresolved Findings of Recovery	22
5. Hold Harmless Clause	23
6. Ohio Workers' Compensation Coverage	24
7. Non-Collusion Affidavit	25
8. Bid Guaranty and Contract Bond	27
VII. Proposal	29
1. Bid Prices	31
2. Wingwall Angles Drawings	32
VIII. Articles of Agreement	34
County Auditor's Agreement	35

ADVERTISEMENT

NOTICE TO BIDDERS

Sealed bids will be received at the Office of the Putnam County Board of Commissioners, 245 E. Main St., Ottawa, OH 45875, until 10:30 AM on Thursday, April 25, 2024 for furnishing all labor, materials and equipment necessary for the:

Road 19—RCB & Wingwalls

and at said time and place, shall be publicly opened and read aloud.

All information for Bidders, specifications, bid documents and maps for this project are posted on the internet and may be viewed and obtained on Putnam County's web page at <https://putnamcountyohio.gov/bid-info/>.

COUNTY OF PUTNAM

Cindy Landwehr, Clerk
Putnam County Commissioners

Michael L. Lenhart, P.E., P.S.
Putnam County Engineer

Bid Advertisement Dates: April 10, 2024
April 17, 2024

INTRODUCTION

It is the intent of these contract documents to serve as the basis for preparing a contractor's estimate of cost, or the contractor's bid; to show engineering intent and to set a level of quality of workmanship and performance; and as the basis for the written contract or agreement between owner and contractor.

They represent the composite of the requirements of the engineer, the owner and any and all funding agencies. An effort has been made, insofar as is practicable, to minimize any duplication or conflict in requirements or standards or performance and workmanship. Inasmuch as this is not always possible, there may be contained herein some conflicting requirements or standards. When such is the case, the more stringent requirements shall always govern, unless stated otherwise. Likewise, Supplemental Provisions will amend and/or add to the Standard Provisions and shall always have precedence over the provisions to which they are a supplement.

The engineer, acting as the owner's representative, shall interpret the intent of the contract documents in a fair and unbiased manner and shall decide any and all questions which may arise to quality and acceptability of materials furnished and work performed.

I. INSTRUCTIONS TO BIDDERS

1. SUBMISSION OF BID

Sealed Bids will be received at the Putnam County Board of Commissioners Office, on or before the advertised Bid date and time, as extended, for all labor, materials, equipment, supervision, coordination and other things necessary for the full and complete performance of the project described by the accompanying Bid advertisement (herein referenced as the "Project").

Bids must be submitted in sealed envelopes marked with the Project title, the name of the Bidder and his address. If forwarded by mail, the sealed envelope containing the bid must be enclosed in another envelope addressed to the Board of County Commissioners 245 E. Main Street, Ottawa, Ohio 45875. Bids shall be opened immediately upon expiration of the Bid submission time, with the names of bidders and their respective bid prices read publicly.

2. STANDARD SPECIFICATIONS & TERMS

The Construction & Material Specifications of the State of Ohio, Department of Transportation (January 1, 2023) shall serve as standard specifications for any contract awarded hereunder. Said Construction & Material Specifications shall be referenced herein as the "Standard Specifications." Supplemental specifications, requirements, terms, conditions and covenants of these Instructions to Bidders and of the accompanying Bid Documents shall control over conflicting terms found in the Standard Specifications.

Wherever the following terms appear in the Standard Specifications, said terms shall have the following meaning:

A. The terms "State," "State of Ohio," "Department" and "Department of Transportation" refer to the County, acting through its Board of Commissioners. The County also may be referenced as the "County" or the "Owner" herein.

B. The term "Director," "DCE" and "DDD" refers to the County Engineer.

C. The term "Engineer" refers to the County Engineer, or to his duly authorized representative.

D. The term "Laboratory" refers to such testing laboratory or consultant as shall be designated by the County Engineer or by the County Engineer's duly authorized representative.

A numerical designation for an "item" referenced herein refers to the description of said item number as provided by the Standard Specifications.

Bidders are specifically referred to the definitions provided by section 101.03 of the Standard Specifications. Any undefined trade and technical words and terms shall be deemed to have the meaning established by trade usage in the highway/bridge construction and civil engineering consultation business.

3. FORM OF BID

Bids shall be submitted using the attached blank forms, designed for such purpose. These forms must be completed intact, without removal of any part, must recite the full name of the party making the Bid, and must be properly signed.

In each blank marked "unit price," bidders are required to provide a Bid price per referenced unit for the requested materials, labor or equipment, or referenced combination thereof. Failure to provide a price for each unit price item, or failure to provide prices for lump sum items, will render the Bid informal, allowing its rejection at the County's discretion.

Extended unit prices are calculated by multiplying the bidder's unit price entries times their respective approximate quantities. The resultant extended unit price figures, in addition to any lump sum prices, are added to calculate the amount of each Bid.

The sum of the unit prices and lump sum prices provided by each Bidder shall comprise that Bidder's Bid price for consideration of award of contract. If an error is made in the extension of unit prices, or in addition of the unit and lump sum prices, the accurate extended unit prices and total shall govern.

Quantities provided by the Bid Documents are estimates only. The Engineer reserves the right to eliminate, increase or decrease the actual quantity of any unit price item or to non-perform any lump sum item.

4. BIDDER QUALIFICATIONS

Prequalification may be granted under any local standards currently used by the County Engineer. In addition, each Bidder shall complete any Bidder qualification forms provided with the Bid Documents and shall furnish documentation and evidence of qualifications as are required thereby. Prequalification by the Ohio Department of Transportation, as described by ORC Sections 5525.02-.09, for performance of Work of the same type, character and magnitude as described hereby, is acceptable.

5. EXAMINATION OF BID DOCUMENTS & SITE OF WORK

Bidders must carefully examine the Bid Documents and perform a reasonable site investigation before submitting a Bid. Submission of a Bid is an affirmative statement that the Bidder has investigated the Project site and is satisfied as to the character, quality, quantities and conditions to be encountered in performing the Work. A reasonable site investigation includes investigating the Project site, borrow sites, hauling roads and all other locations related to the performance of the Work.

6. BID GUARANTEE

Each Bid shall be accompanied by a bid guarantee, in the form of a bid bond, a certified check, a cashier's check or a letter of credit, in conformity with the requirements of ORC 153.54 and 153.571 (B). If a bid bond is used, the bond shall be in the full amount of the bid and signed by a Surety company authorized to do business in Ohio and accompanied by the Surety's sufficient power of attorney affirming said signature. If a certified check, cashier's check or letter of credit is used, the instrument shall be drawn

on a solvent bank in an amount not less than ten percent (10%) of the Bid. The bid guarantee shall be given as security that, if the Bid is accepted, the Bidder will enter into a contract in conformity with the Bid. Bids less than twenty-five thousand dollars (\$25,000.00) do not require a bid guarantee.

7. FACTORS FOR ACCEPTANCE OR REJECTION OF BIDS

A. Pursuant to ORC 307.90 (A), a contract shall be awarded to the lowest and best Bid.

B. Any Bid which is incomplete, conditional, obscure, or which contains additions not called for or irregularities of any kind, may be rejected.

C. The Board of Commissioners reserves the right to reject any and all Bids, and also the right to waive any informality in the Bid. The Board of Commissioners has the right to postpone the decision to award a contract for up to sixty (60) days.

D. No contract shall be awarded to any person, firm or corporation that is in arrears or is in default to the County upon any debt or contract, or that is in default as surety or otherwise upon any obligation to the County or has failed to perform faithfully any previous contract with the County, or that has an unresolved finding of recovery with the State Auditor or has been debarred by the County from consideration for contract awards.

E. A conditional or qualified Bid will not be accepted.

F. Award will be made to one Bidder per proposal.

8. WITHDRAWAL OF BIDS

A Bidder may request, in writing, to withdraw its Bid within five business days of the opening. Such requests will be reviewed by the Board of Commissioners for approval as permitted by ORC 9.31 and 153.54 (G). If approved, collection of the bid guarantee or bond will be waived.

9. PREVAILING WAGE RATES

All employees on the Work site shall be paid at the prevailing wage rate for the appropriate class of Work. The prevailing wage rates shall be determined in accordance with ORC Chapter 4115, except for employees who are covered by a collective bargaining agreement in existence prior to the date of contract, who shall be paid the rate of pay provided by such agreements. Schedules of applicable prevailing wage rates are attached to the Specifications. Bidders are cautioned to assure the completeness of said wage schedules, and to notify the County Engineer prior to the bid date of any omitted schedules.

10. OTHER COSTS & REQUIREMENTS

Bids must include all costs of performing the Work and all costs of fulfilling the requirements of laws, rules and regulations pertaining thereto. The following is a partial list of ancillary contract costs and requirements. Said list is provided for the convenience

of Bidders, to assist in their inclusion of all components of costs and fulfillment of all requirements, though this list does not recite all such costs and requirements.

A. Bids must include the cost of all required bonds (performance and maintenance).

B. Bids must include the cost to procure all permits and licenses, to pay all charges, fees and taxes, and to provide all notices necessary and incidental to the due and lawful prosecution of the Work.

C. Bids must include the cost of insurance coverage of the type and at least in the amounts set forth by section 107.12 of the Standard Specifications and by any special bid provisions.

D. The County is exempt from all sales, excise, and transportation taxes, with the exception of State of Ohio gasoline tax. Bid prices shall exclude all such taxes. **Upon request, the County will fill out a tax exempt certification.**

E. "Declaration of Personal Property Tax Delinquency" form must be fully executed and notarized pursuant to ORC Section 5719.042, before an award can be made.

II. SUPPLEMENTAL CONTRACT PROVISIONS

1. AWARD REQUIREMENTS OF SUCCESSFUL BIDDER/CONTRACTOR

The following is a partial list of award contract requirements. Said list is provided for the convenience of Bidders, to assist in their inclusion of all components of costs of such requirements, though this list does not recite all such costs and requirements.

A. The successful Bidder/Contractor must provide a one hundred percent (100%) Performance Bond based on the contract amount, in conformity with the requirements of ORC section 153.54 (C) and 153.57 (A). A Maintenance Bond in the amount to ten percent (10%) of the final contract amount, extending coverage for one (1) year beyond the acceptance date of the completed Project, must be provided by the Contractor as a prerequisite to final payment. Said Maintenance Bond shall assure the repair and/or correction of any defects, deficiencies or omissions in the Project Work.

B. The Contractor must provide evidence of all insurance coverage requirements of section 107.12 of the Standard Specifications.

C. The Contractor agrees to provide the County with full and complete documentation of payment of prevailing wages to all employees of the Contractor and of its subcontractors governed by Prevailing Wage law.

D. The Contractor agrees to provide the County with a contact person, a telephone number, a mailing address and, if available, an electronic mail address for purposes of giving notice to the Contractor of any changes in prevailing wage rates. Where an electronic mail address is given, the Contractor agrees that the use of that method by the County satisfies any notice requirements of any change in prevailing wage rates. Upon commencement of contract work, the Contractor and its subcontractors subject to the contract's prevailing wage requirements must provide the prevailing wage coordinator with a schedule of wages, with certified copies of payroll being required throughout work on the Project.

E. The Contractor further agrees to stay informed of applicable prevailing wage rates and to immediately inform all its subcontractors and the Engineer of such changes. The Contractor agrees to defend and indemnify the County, its elected officials, agents and employees, against all claims, actions, demands, judgments, settlements, damages, liabilities, losses, and costs of any kind, including, but not limited to, reasonable fees of attorneys and experts, arising from or related to the Contractor's failure to inform its subcontractors of changes in prevailing wage rates.

F. The Contractor must furnish the County with a completed IRS Form W-9, "Request for Taxpayer Identification Number & Certification." The Internal Revenue Code requires the County to file an information return each January 31st on all payments made the previous year of \$600.00 or more. As required by Section 3406 of the Internal Revenue Code (26 U.S.C. 3406), the County shall withhold federal taxes of a rate of thirty-one percent (31%) if a correct taxpayer identification number is not provided. Back-up withholding requirements continue until the required information is received.

2. OTHER CONTRACTOR DUTIES

In addition to the duties cited by the Standard Specifications and elsewhere in these Bid Documents, the Contractor has the following duties:

A. When determined necessary by the Engineer, the Contractor shall provide a field office, suitably and of ample size and accommodations, from which the Engineer's inspections, as well as the Contractor's Work, may be carried out. The Contractor must keep a full set of Plans and Specifications available at the field office.

B. The Contractor must furnish, without extra compensation therefore, such assistance as the Engineer, or his assistants or inspectors may require, in measuring in and setting stakes or marks for indicating lines, grades or levels, for measuring or determining quantities for estimates, and for handling and inspecting materials to be used on the Work, whether such materials have been delivered upon the site of Work or are in local storage. The Contractor shall provide such facilities for weighing and measuring materials as the Engineer may deem necessary, to secure the proper fulfillment of the provisions and requirements of the Specifications.

C. The Contractor shall diligently protect and preserve all stakes, marks, bench marks and monuments set or used by the Engineer and shall be responsible for securing therefore the proper lines, grades and levels for the structures to be built.

D. The Contractor must place or construct, in such manner and at such points as the Engineer may require, necessary sanitary conveniences for the use of employees on the Work site. They shall be properly secluded from public observation, shall be maintained sanitary and inoffensive at all times, and their use shall be strictly enforced. The Contractor must provide an ample supply of pure drinking water for employees at all times, and the source of such supply shall be subject, at all times, to the approval of the Engineer.

E. The Contractor is reminded of its duty to notify the registered underground utility protection service and owners of underground utility facilities at least two working days in advance of commencement of construction operations that may involve such facilities, to allow surface marking of facility locations.

F. The Contractor shall, using the U.S. government's System for Awards Management (SAM), ensure that any project subcontractors are not on the excluded parties list. The Engineer will also check all project subcontractors using the System for Awards Management. <https://www.sam.gov/>

3. DISCRIMINATION PROHIBITED

The Contractor understands and agrees that, in the hiring of employees for the performance of work under the contract or any subordinate contract hereunder, the Contractor, its subcontractors and persons acting on behalf of the same shall not discriminate in the hiring or retention of subordinate contractors or employees "by" or "for" reason of race, creed, sex, disability (as defined by ORC 4112.01) or color; nor shall said parties discriminate against any citizen of the State of Ohio in the employment of labor or workers who otherwise qualify and who are available to perform the work to which the contract relates.

Further, the Contractor and its subcontractors and persons acting on behalf of the same shall not discriminate against or intimidate any employee hired for performance of the Work under the contract on account of race, creed, sex, disability (as defined by ORC (4112.01) or color.

In addition, the Contractor agrees, as a prerequisite of award, to complete the attached "Equal Employment Opportunity Compliance Certificate," and to fulfill all requirements thereof.

4. INSPECTION

The Engineer, assistants and agents shall have, at all times, immediate access and right to enter upon the Work site and other Work premises occupied by the Contractor as well as upon the site of all sources from which materials are being obtained for the contract. The Contractor shall provide safe and proper facilities for permitting such entrance and for inspecting and testing purposes. Subcontractors and suppliers shall have similar obligations imposed by subordinate contracts. The Contractor shall furnish the Engineer with all reasonable facilities for ascertaining that the materials and Work are in accordance with the requirement and intention of the Specifications and contract, even to the extent of uncovering or removing portions of finished Work.

The Contractor shall give definite information, at any time, as to the place from which, or persons from whom, any material is being or will be procured. All materials to be used may be subjected to such tests as the Engineer may require assuring that such materials conform, in all respects, to the requirements of the Specifications, or that they are equal to samples submitted by the Contractor. All materials which do not conform to such requirements shall be rejected, and the Contractor shall remove such rejected materials from the vicinity of the Work within twenty-four (24) hours thereafter.

The inspection and supervision of the Work and materials by the Engineer, assistants and inspectors is intended to aid the Contractor in accomplishing the fulfillment of duties and obligations under the contract, but such inspection and supervision shall not relieve the Contractor from contract obligations.

Defective Work shall be made good and unsuitable materials may be rejected, notwithstanding that such Work and materials have been previously overlooked by the Engineer and accepted or estimated for payment. If the Work, or any part thereof, is found, at any time before the acceptance of the whole Work and for the period of the Maintenance Bond thereafter, to be defective, or to contain defective materials, the Contractor shall make good such defects under the direction of the Engineer.

Upon being attached to, or incorporated in the Work, or affixed in or to the soil, all materials shall become property of the County. Thereafter the Contractor shall have no right of property therein, unless they are afterward rejected by the Engineer. The Contractor bears risk of loss of and damage to the Work until completion and final acceptance of the Work.

The Contractor shall schedule inspection 24 hours in advance of the performance of the respective Work. At the pre-construction meeting, the Engineer shall provide the Contractor with phone numbers and names of a contact person and of the Engineer's

inspectors. The Contractor shall inform the Engineer of his Work schedule and the hours of operation before the Contractor may begin Work.

When Work is scheduled and the Contractor desires to change the approved schedule, the Contractor shall contact the Engineer's inspector at or before 7:30 a.m. of the scheduled Work date to cancel or adjust the hours of inspection. If the Contractor fails to contact the Engineer's inspector as stated above or if the notice is within two (2) hours of the scheduled inspection and is insufficient to cancel attendance by the Engineer's inspector, the Contractor will be charged for two (2) hours of inspection time at the current inspection rate. This cost will be subtracted from the Contractor's monthly pay estimate.

5. CHANGES IN QUANTITY OF WORK

The quantities of Work, as given in the Estimated Quantities, are approximations only. The County Engineer shall have the power to alter by increasing, decreasing or deleting the quantities of Work to be done, either before or after the commencement of construction.

If such changes involve the reduction or omission of any material or Work called for by the original Plans or Specifications, there shall be no right with the Contractor for any claims for losses or damages, for loss of profit, growing out of omission. If any such change involves additional material or labor, upon which the price is fixed in the Contract, that price shall govern. Any such change shall in no way relieve the Contractor of or affect any of the obligations hereunder. In like manner, the County may, without affecting the contract, require the Contractor to furnish materials or to do Work for which no price is given as provided by the Standard Specifications.

If such changes result in increased or diminished expense of Work items, the prices of which are fixed in the contract, the County Engineer shall determine an equitable adjustment of such prices, which shall be final and binding on the parties hereto, subject to dispute resolution.

6. SIGNIFICANT CHANGES IN CHARACTER OF THE WORK.

The Engineer may alter the Work as necessary to complete the Project. The Engineer will make appropriate adjustments according to 108.06 and 109.05, if such alterations significantly change the character of the Work.

If the alterations or changes in quantities significantly change the character of the Work under the Contract, whether such alterations or changes are in themselves significant changes to the character of the Work or by affecting other Work cause such other Work to become significantly different in character, an adjustment, excluding anticipated profit, will be made to the Contract. Before performing significantly changed Work, reach agreement with the Department concerning the basis for the adjustment. If the Contractor disagrees as to whether an alteration constitutes a significant change, use the notification procedures specified in 104.02.G.

The term "significant change" is defined as the follows:

1. when the character of the Work as altered differs materially in kind or nature from that involved or included in the original proposed construction; or

2. when the product of the quantity in excess of the estimated quantity of a contract item and the unit price exceeds the limits set forth in Table 104.02-1. If the increase does not exceed the limits set forth in Table 104.02-1, then the Department will pay for the increased Work at the Contract Price.

Table 104.02-1

Contract Price	Contract Limits
Up to \$500,000	\$25,000
\$500,001 to \$2,000,000	5% of Total Contract Price
Over \$2,000,000	\$100,000

If the decrease in quantity of any unit price Contract Item exceeds 25 percent of the estimated quantity, and the total of all such adjustments for all Contract Items is more than \$400, then after the determination of final quantities according to 109.12.C, the Engineer will adjust the unit prices for the affected Contract item by multiplying the bid unit price by the factor obtained from Table 104.02-2.

Table 104.02-2

% Decrease	Factor	% Decrease	Factor
25 to 28	1.02	61	1.14
29 to 32	1.03	62	1.15
33 to 35	1.04	63	1.16
36 to 38	1.05	64	1.17
39 to 41	1.06	65	1.18
42 to 44	1.07	66	1.19
45 to 47	1.08	67	1.20
48 to 50	1.09	68	1.21
51 to 53	1.10	69	1.22
54 to 56	1.11	70	1.23
57 to 59	1.12	71	1.24
60	1.13	72 and over	1.25

7. NO WAIVER RIGHTS

No act of the Engineer, or his assistants or inspectors, shall operate as waiver of any provisions of the contract, nor shall any breach of this contract operate as a waiver of any other subsequent breach. Any and all remedies provided in this contract are cumulative, in addition to other remedies herein provided. The mention of any specific liability or duty of the Contractor, in any part of the Specifications or contract, shall not be construed as a limitation or restriction upon general liability or duty imposed upon the Contractor by said Specifications and contract. Should any part of the Work be sublet by the Contractor, such action shall in no way release the Contractor from liability or obligation hereunder. The Contractor shall be liable for the acts, omissions and negligence of any subcontractor, and shall be responsible therefore as though no subcontract existed.

8. DAMAGES FOR LATE COMPLETION; EXTENSIONS OF TIME

Time is of the essence to this contract. The rate of progress shall be such as to complete the Project Work within the time limit specified herein. **The completion date for this project is: July 31, 2024.**

In the event that the Work is not completed within the time limit aforesaid, the Contractor shall reimburse the County an amount equal to the County's costs for and expenses of Project inspections, supervision and similar engineering services provided by or for the County after the expiration of the aforesaid time limit, and until completion and acceptance of the Work.

In addition, in the event that the Work is not substantially completed within the time limit aforesaid, with said incompleteness prohibiting beneficial use and occupancy of the Project, in compensation for the public's loss of use of the Project, the Contractor shall forfeit liquidated damages in the amount set forth by section 108.07 of the Standard Specifications.

Such amounts shall be deducted by the Engineer from the partial or final estimates to be allowed the Contractor.

The Board of County Commissioners may for good cause shown, extend the time of completion. Any such extension in time shall not be deemed a waiver by the County of any other rights provided for under this contract and shall not operate to release any Surety from any bond obligations.

9. NIGHT, SUNDAY & HOLIDAY WORK

No Work will be permitted on Sundays or legal holidays, except as authorized by the Engineer or the Board of Commissioners. No Work will be permitted after dark except under terms and conditions agreed to in writing by the Engineer, Board of Commissioners and Contractor. No extra compensation will be allowed to the Contractor for night, Sunday or Holiday Work, regardless of cause of such Work.

10. PARTIAL PAYMENTS

Before the day, stipulated by the Owner, of each month, the Contractor shall make a written estimate of the amount of value of the work and materials incorporated into the work during the preceding month, broken down into bid items. The Contractor shall submit his estimate to the Engineer immediately upon its preparation, and after each such partial estimate has been certified to in writing by the Engineer the owner shall, on or before the first day of the month next following, pay the Contractor as specified below.

No partial payment will be made when the amount due the Contractor since the last estimate amounts to less than five hundred dollars.

From the total of the amount determined to be payable on a partial payment, 8 percent of the first 50 percent of such total amount will be deducted and retained by the Owner until the final payment is made except. The balance of the amount payable, less all previous payments, shall be certified for payment.

Upon completion and acceptance of the project by the Owner and Engineer, (i.e., the signing of the "Certification of Substantial Completion" by all parties involved), the Owner shall release one half (1/2) of the retainer. The remaining one half (1/2) of the retainer shall be retained by the Owner for the following periods after the date of approval and acceptance of the project.

<u>Acceptance Date</u>	<u>Period</u>
From Feb. 15 to Aug. 15	90 Calendar Days
From Aug. 16 to Feb. 14	180 Calendar Days

The owner agrees that upon expiration of the above period, the Contractor shall be entitled to the whole sum of the reserve, less any part expended by the Owner in making repairs.

Should any defective work or material or acceptable work that has been damaged by the Contractor's operations be discovered previous to the final acceptance or should a reasonable doubt arise previous to the final acceptance as to the integrity of any part of the completed work, the estimate and payment for such defective or questioned work shall not be allowed until the effect has been remedied and cause for doubt removed.

It is understood and agreed that the Contractor shall not be entitled to demand or receive partial payment based on quantities of work in excess of those provided in the proposal or covered by approved change orders or supplemental agreements, except when such excess quantities have been determined by the Engineer to be a part of the final quantity for the item of work in question.

No partial payment shall bind the owner to the acceptance of any materials or work in place as to quality or quantity. All partial payments are subject to correction at the time of final payment.

III. SCOPE OF WORK

1. GENERALLY

The Contractor shall furnish, at its own cost and expense, all management, labor, tools, forms, equipment, appliances, machinery, transportation, materials and other things necessary, of whatever nature, to perform the Work, and shall perform and complete, within the time limit specified, all of the Work indicated or implied by the Notice to Bidders, Instructions to Bidders, General & Supplemental Provisions, Standard Specifications, Scope of Work, Plans & Specifications, and Estimated Quantities prepared for this Project, including the removal of surplus or condemned materials, and the thorough cleaning of the site of the Work and structures built.

In no case will any Work, in excess of such requirements, be paid for unless ordered in writing by the County Engineer as hereinafter specified.

All Work shall be of the best quality throughout. Unless otherwise provided herein, all materials shall be new.

2. SCHEDULE OF PERFORMANCE

At the pre-construction meeting, the Contractor must provide the Engineer with a printed schedule showing the interrelation and planned performance of all major items of Work, with completion reasonably scheduled thereon to occur by the scheduled completion date recited herein. The Engineer shall review and consider acceptance of the schedule as provided by section 108.02 (B) (1) of the Standard Specifications.

IV. PLANS & SPECIFICATIONS

1. GENERALLY

The Plans and Specifications are intended to explain and supplement each other, and to indicate and provide for the construction of the various related parts of the Project in a complete and connected manner. Should any detail be omitted, any discrepancies or errors appear, or misunderstandings arise, in or with respect to such Plans and Specifications, the additions, corrections, or explanations necessary to provide for the construction in accordance with such intent shall be made by the Engineer, and such additions, corrections and explanations shall be final and binding upon the Contractor, subject to dispute resolution.

2. "OR EQUAL"

Whenever an article, material or equipment is defined herein by describing a proprietary product, or by using the name of manufacturer or vendor, the term "or equal", if not inserted, shall be implied. The specific article, material or equipment mentioned shall be understood as indicating the type, function, minimum standard of design, efficiency and quality desires and shall not be construed in such a manner as to exclude manufacturer's products of comparable quality, design and efficiency. The Contractor shall comply with the requirements of the contract documents, relative to the approval of materials and equipment by the County, before the same are incorporated in the Work.

3. LIST OF PLANS & SPECIFICATIONS

See attached drawings.

V. PREVAILING WAGE RATE SCHEDULES

PN060-PROJECTS WITH NO FEDERAL AID

The following is in addition to Section 108.10

This contract is subject to Ohio Prevailing Wage Laws, Chapter 4115 of the Ohio Revised Code and the Contractor and all subcontractors shall comply with all provisions contained therein or as otherwise provided by this note. The Contractor guarantees that the prevailing wage scale to be paid to all laborers and mechanics employed on this contract shall be in accordance with the schedule of the prevailing hourly wage and fringe benefits as determined by the Ohio Department of Commerce for the county in which the work is being performed. Failure to pay prevailing wages to all laborers and mechanics employed on this project shall be considered a breach of contract. Such a failure may result in the revocation of the contractor's and/or subcontractor's certificate of qualification and debarment. A schedule of the most current prevailing wage rates may be accessed by registering with the Ohio Department of Commerce, Labor and Worker Safety Division, Wage and Hour Bureau at the following web address:

<http://198.234.41.198/w3/webwh.nsf?Opendatabase>

The Contractor and all subcontractors shall compensate the employees on this contract at a pay rate not less than the hourly wage and fringe rate listed on the website noted above, for the applicable job classification or as modified by the Ohio Department of Commerce, Division of Labor and Worker Safety Wage and Hour Bureau, when new prevailing rates are established.

Overtime shall be paid at one and one-half times the basic hourly rate for any hours worked beyond forty (40) hours during a pay week. The Contractor and all subcontractors shall pay all compensation by company check to the worker and fringe benefit program.

The wage and fringe rates determined for this project or as may be later modified, shall be posted by the Contractor in a prominent and accessible place on the project, field office, or equipment yard where they can be easily read by the workers or otherwise made available to the workers. On the first pay date of contract work the Contractor and all subcontractors shall furnish each employee covered by prevailing wage a completed form whpw1512 in accordance with section 4115.05 Ohio Revised Code, showing the classification, hourly pay rate, fringes, and identifying the District Prevailing Wage Coordinator (DPWC), if such employees are not covered by a collective bargaining agreement or understanding between employers and bona fide organizations of labor. These forms shall be signed by the Contractor or subcontractor and the employee and kept in the Contractor's or subcontractor's payroll files.

The Contractor and all subcontractors shall submit to the DPWC or other designated Department representative, certified payrolls on form whpw1509 or equivalent, in accordance with sections 4115.07 and 4115.071(C) of the Ohio Revised Code, three (3) weeks after the start of work and every subsequent week until the completion of the contract. Additionally, a copy of the "Apprentice Certification" obtained from the USDOL Bureau of Apprenticeship and Training must accompany the first certified payroll submitted for all apprentices working on this project. Upon completion of the contract and before the final payment, the Contractor shall submit to the DPWC a final wage

affidavit in accordance with section 4115.07 of the Ohio Revised Code stating that wages have been paid in conformance with the minimum rates set forth in the contract. Please be aware that it is ultimately the responsibility of the prime Contractor to ensure that all laws relating to prevailing wages in Chapter 4115 of the Ohio Revised Code, are strictly adhered to by all subcontractors.

The Contractor and all subcontractors shall make all of its payroll records available for inspection, copying or transcription by any authorized representative of the contracting agency. Additionally, the Contractor and all subcontractors shall permit such representatives to interview any employees during working hours while the employee is on the job.

If the Contractor or any subcontractor fails to comply with any of the provisions contained in this proposal note, the Department may terminate the contract, debar the Contractor or subcontractor and/or withhold or suspend pay estimates after written notice and a reasonable opportunity to comply has been provided.

List the largest performance bonds you have obtained in the past three years.

Date	Owner and Location	Amount of Bond	Type of Work Done	Required Date of Completion

Are there any outstanding liens against you or your projects? _____

If answer is yes to any of the above, please furnish details. (If there is insufficient space on this page, attach additional sheets.)

AFFIRMATION OF BIDDER QUALIFICATIONS FORM

I, the undersigned, hereby affirm that I am an officer or sole proprietor of the Bidder identified below, that I am duly authorized by said Bidder to execute this document, and that the answers given on the Bidder Qualifications forms are complete and true.

Signed this _____ day of _____, 20____.

Bidder: _____

(Signed) _____

Printed Name: _____

Title: _____

**EQUAL EMPLOYMENT OPPORTUNITY REQUIREMENTS
FOR SERVICE AND SUPPLY CONTRACTS**

EQUAL OPPORTUNITY COMPLIANCE CERTIFICATE

As used in the Certificate, the terms “contract” and “subcontract” includes the term “Purchase Order” and all other agreements effectuating purchase of supplies or services.

This Certificate shall be renewed annually. Notwithstanding the foregoing, the certifications made herein shall remain applicable until completion of all non-exempt contracts/subcontracts awarded while this Certificate is in effect. The undersigned Bidder certifies the following to the County:

A. **REPORTS:** Within thirty (30) days after the County’s award to the Bidder of any contract, and prior to each March 31 thereafter, during the performance of work under said contract, the Bidder shall file Standard Form 100, entitled “Equal Employment Opportunity Employer Identification Report EEO-1” in accordance with instructions contained therein, unless the Bidder has either filed such report with the County within twelve (12) months preceding the date of the award or is not otherwise required by law or regulations to file such a report.

B. **PRIOR REPORTS:** The Bidder, if it has participated in a previous contract or subcontract subject to the Equal Employment Opportunity Clause 41 C.F.R. Sec. 60-1.4 (a) (1) through (7), or the clause originally contained in Section 301 or Executive Order No. 10925, or the clause contained in Section 201 if the Executive Order No. 11114, has filed all required compliance reports. The Bidder shall obtain similar representations indicating submission of all required compliance reports, signed by proposed subcontractors, prior to awarding subcontracts not otherwise exempt from the Equal Employment Opportunity clause.

C. **CERTIFICATION OF NON-SEGREGATED FACILITIES:** The Bidder certifies that it does not maintain or provide for its employees any segregated facilities at any of its establishments, and that it does not permit its employees to perform their services at any location, under its control, where segregated facilities are maintained. The Bidder certifies further that it will not maintain or provide for its employees any segregated facilities at any of its establishments and that it will not permit its employees to perform their services at any location, under its control, where segregated facilities are maintained. The Bidder agrees that a breach of this certification is a violation of the Equal Employment Opportunity Clause in this Certificate. As used in the certification, the term “segregated facilities” means any waiting rooms, rest rooms, and wash rooms, restaurants and other eating areas, time clocks, locker rooms and other storage or dressing areas, parking lots, drinking fountains, recreation or entertainment areas, transportation, and housing facilities provided for employees which are segregated by explicit directive or are in fact segregated on the basis of race, color, religion or natural origin, because of habit, local customs or otherwise. The Bidder further agrees that (except where it has obtained certifications from proposed subcontractors for specific time periods) it will obtain identical certifications from proposed subcontractors prior to award of any subcontracts exceeding \$10,000.00 which are not exempt from the provisions of the Equal Employment Opportunity Clause; that it will retain such

certifications in its files; and that it will forward the following notice to such proposed subcontractors (except where the proposed subcontractors have submitted identical certifications for specific time periods):

Notice to Prospective Subcontractors of Requirement for Certification of Non-segregated Facilities: A Certification of Non-segregated Facilities, as required by Section 60-1.8 of Title 41 of the Code of Federal Regulations, must be submitted prior to the award of a subcontract exceeding \$10,000.00 which is not otherwise exempt from the provisions of the Equal Employment Opportunity Clause.

NOTE: The penalty for making false statements in offers is prescribed in 18 U.S.C. 1001.

D. **AFFIRMATIVE ACTION COMPLIANCE PROGRAM:** Prior to 120 days after receipt of any contract in the amount of \$50,000.00 or more from the County, Bidder, if it has fifty (50) or more employees and is not otherwise exempt under 41 C.F.R., Part 60-1, shall have developed for each of his establishments a written affirmative action compliance program as called for in 41 C.F.R., Sec. 60-1.40. Bidder will also require its lower-tier subcontractors who have fifty (50) or more employees and receive a subcontract of \$50,000.00 or more and who are not otherwise exempt under C.F.R., Part 60-1 to establish written affirmative action compliance programs in accordance with 41 C.F.R., Section 60-1.40.

E. Bidders are responsible to EEO compliance as provided in Executive Order 11246 and implementing regulations Title 41, Chapter 60-4.2, 60-4.3 (Equal Employment Opportunity Clause & Notification of Standard Specifications), 60-250, and 60-741, when applicable.

F. Bidder certifies that it is not currently in receipt of any outstanding letters of deficiencies, show cause, probable cause or other such notifications or noncompliance with EEO regulations.

Signed this _____ day of _____, 20____.

Bidder: _____

(Signed) _____

Printed Name: _____

Title: _____

DECLARATION OF PERSONAL PROPERTY TAX DELINQUENCY

OHIO REVISED CODE 5719.04

I, the undersigned, hereby affirm that the bidder identified below IS/IS NOT (please circle the one that applies) charged at the time of submitting this Bid with any delinquent personal property taxes on the general tax list of personal property of the County.

COMPLETE THIS PARAGRAPH ONLY IF APPLICABLE:

The amount of any such due and unpaid delinquent tax and any due and unpaid penalties and interest is \$_____.

Signed this _____ day of _____, 20____.

Bidder:_____

(Signed)_____

Printed Name:_____

Title:_____

STATE OF OHIO)
COUNTY OF _____) ss:

Before me, a Notary Public, in and for said County, personally appeared the person identified above, who did sign this document after first affirming that the execution of this document was an authorized act on behalf of the above Bidder.

IN TESTIMONY WHEREOF, I have affixed my hand and the seal of my office at this _____ day of _____, 20____.

NOTARY PUBLIC

**CERTIFICATE OF BIDDER
UNRESOLVED FINDINGS OF RECOVERY
WITH AUDITOR OF STATE
ORC 9.24 & 9.241**

I, the undersigned, hereby affirm that the Bidder identified below:

CHECK & COMPLETE ONLY ONE

has no unresolved findings of recovery with the State of Ohio Auditor, as defined by;
ORC 9.24 & 9.241

has the following unresolved findings of recovery with the State of Ohio Auditor, as
Defined by ORC 9.24 & 9.241:

Signed this _____ day of _____, 20____.

Bidder: _____

(Signed) _____

Printed Name: _____

Title: _____

HOLD HARMLESS CLAUSE

Putnam County, Ohio

INDEMNITY: To the maximum extent allowed by Ohio law, the Contractor shall defend, indemnify, and hold harmless the County and the Owner (i.e.: county, township, and/or municipality), if applicable, (hereinafter: the indemnified parties), and all of their elected and appointed officials, together with all their employees and agents from any and all claims, demands, causes of action, judgments, liens, penalties, costs, and expenses (including attorney fees and expenses) of any kind, including claims for bodily injury, illness, death, property damage, or loss of use, which may at any time be imposed upon, incurred by, or asserted against the indemnified parties as a result of any action of the Contractor, its officers, employees, invitees, or agents arising out of or in consequence of this Agreement, including, but not limited to: 1.) The performance or non-performance of the work or any obligation under this Agreement; 2.) The common law or any legislation, regulation or order including environmental laws, rules, and orders; or 3.) Negligence including any passive negligence of the indemnified parties. This indemnification shall survive any termination of this Agreement and is not limited by the Contractor's insurance coverage. In order to effectuate and facilitate the indemnification of the indemnified parties, Contractor does hereby waive any and all employer immunity provided by the workmen's compensation law under Section 35, Article II, of the Ohio Constitution. At the option of the indemnified parties, Contractor shall provide the indemnified parties with legal counsel, and shall further bear all costs and expenses including attorney fees in the defense of any suit arising hereunder. Additionally, Contractor shall repair or pay for the repair of any damage to the indemnified parties' property caused by the Contractor or its officers, employees, invitees, or agents.

INSURANCE: Contractor at its sole cost and expense shall furnish and keep in full force and effect during the time this Contract is in effect sufficient insurance to protect the indemnified parties from any claim arising from the Contractor's conduct as a result of this Agreement, including: workers' compensation coverage in compliance with State law; comprehensive general and motor vehicle liability insurance (including coverage for owned, non-owned or hired vehicles) with broad form property damage coverage with limits of at least \$1,000,000.00 for bodily injury or death per occurrence and \$1,000,000.00 aggregate, \$1,000,000.00 property damage per occurrence and \$1,000,000.00 aggregate (or a reasonable equivalent expressly accepted by the indemnified parties), plus loss insurance for the equipment used. If the above insurance sums are blank, Contractor shall provide insurance as specified. Such liability insurance policies shall insure the contractual liability assumed hereunder, shall name the indemnified parties as additional insured parties for all work under this Contract, and shall provide that such insurance is primary to any other of indemnified parties' liability insurance. Prior to commencing any work, Contractor shall furnish the indemnified parties with proof of such insurance with companies acceptable to the indemnified parties.

OHIO WORKERS' COMPENSATION COVERAGE

The Contractor must secure and maintain valid Ohio workers' compensation coverage until the County, as set forth in Section 109.12(E) of the Construction and Material Specifications Manual, has finally accepted the Project. A certificate of coverage evidencing valid workers' compensation coverage must be submitted to the County before the Contract will be executed.

The Contractor must immediately notify the County, in writing, if it or any subcontractor fails or refuses to renew their workers' compensation coverage. Furthermore, the Contractor must notify the County, in writing, if its or any of its subcontractor's workers' compensation policies are cancelled, terminated, or lapse.

The failure to maintain valid workers' compensation coverage shall be considered a breach of contract, which may result in the Contractor being removed from the Project, withholding of pay estimates and/or termination of the Contract.

NON-COLLUSION AFFIDAVIT

TO BE EXECUTED BY EACH AWARDEE OF A PRINCIPAL CONTRACT

)
)§
)

_____, being first duly sworn, deposes and says that he is _____(sole owner, a partner, president, secretary, etc.) of _____ (company name).

The party making the foregoing bid; that such bid is not made in the interest of or on behalf of any undisclosed person, partnership, company, association, organization or corporation; that such bid is genuine and not collusive or sham; that said bidder has not directly or indirectly induced or solicited any other bidder to put in a false or sham bid, and has not directly or indirectly colluded, conspired, connived or agreed with any bidder or anyone else to put in a sham bid, not that anyone shall refrain from bidding; that said bidder has not in any manner, directly or indirectly, sought by agreement, communication or conference with anyone to fix the bid price of said bidder or of any other bidder, nor to fix any overhead, profit or cost element of such bid price, nor that of any other bidder, nor to secure any advantage against the public body awarding the contract to anyone interested in the proposed contract; that all statements contained in such bid are true; and further, that said bidder has not, directly or indirectly, submitted his bid price or any breakdown thereof, not the contents thereof, nor divulged any information or data relative thereto, nor paid and will not pay fees in connection therewith to any corporation, partnership, company, association, organization, bid expository, nor to any member or agent thereof, nor to any other individual except to such person or persons as have a partnership or other financial interest with said bidder in his general business.

(Signed)_____

Printed Name:_____

Title:_____

Subscribed and sworn to before me this ____ day of _____, 20__.

Notary Public

NON-COLLUSION AFFIDAVIT

TO BE EXECUTED BY EACH "AWARDEE" OF A SUBCONTRACT

)
)§
)

_____, being first duly sworn, deposes and says that he is _____(sole owner, a partner, president, secretary, etc.) of _____ (company name) the party submitting a bid for a subcontract covering _____ (nature of the subcontract) that such bid is not made in the interest of or on behalf of any undisclosed person, partnership, company, association, organization or corporation; that such bid is genuine and not collusive or sham; that said bidder has not directly or indirectly induced or solicited any other bidder to put in a false or sham bid, and has not directly or indirectly colluded, conspired, connived or agreed with any bidder or anyone else to put in a sham bid, not that anyone shall refrain from bidding; that said bidder has not in any manner, directly or indirectly, sought by agreement, communication or conference with anyone to fix the bid price of a said bidder or of any other advantage against the principal contractor or anyone interested in the proposed subcontract; that all statements contained in such bid are true; and further, that said bidder has not, directly or indirectly, submitted his bid price or any breakdown thereof, nor the contents thereof, nor divulged any information or data relative thereto, nor paid and will not pay fees in connection therewith to any corporation, partnership, company, association, organization, bid expository, nor to any member or agent thereof, nor to any other individual except to such person or persons as have a partnership or other financial interest with said bidder in his general business.

The provisions of the affidavit shall not be held as disqualifying a person, firm or corporation who has submitted a sub-proposal to one bidder from submitting separate sub-proposals or quoting prices for materials or work to other bidders.

(Signed)_____

Printed Name:_____

Title:_____

Subscribed and sworn to before me this ____ day of _____, 20__.

Notary Public

**BID GUARANTY AND CONTRACT BOND
(Section 153.571 Ohio Revised Code)**

KNOW ALL MEN BY THESE PRESENTS, that we, the undersigned

_____ (Name & Address) as
Principal, and _____ (Name) as
Sureties, are hereby held and firmly bound unto the BOARD OF PUTNAM COUNTY
COMMISSIONERS, hereinafter called the Oblige, in the penal sum of the dollar amount
of the bid submitted by the Principal to the Owner on **April 25, 2024** to undertake the
project known as **Road 19—RCB & Wingwalls**.

The penal sum referred to herein shall be the dollar amount of the Principal's bid to the
Oblige, incorporating any additive or deductive alternate proposals made by the
Principal on the date referred to above to the Oblige, which are accepted by the
Oblige. In no case shall the penal sum exceed the amount of:
_____ dollars (\$_____). (If the
foregoing blank is not filled in, the penal sum will be the full amount of the Principal's bid,
including alternates. Alternatively, if the blank is filled in, the amount stated must not be
less than the full amount of the bid including alternates, in dollars and cents. A
percentage is not acceptable.) For the payment of the penal sum will and truly be made,
we hereby jointly and severally bind our heirs, our executors, administrators, successors,
assigns and ourselves.

THIS CONDITION OF THE ABOVE OBLIGATION IS SUCH that whereas the above-
named Principal has submitted a bid to the above referred to project.

Now, therefore, if the Oblige accepts the bid of the Principal and the Principal fails to
enter into a proper contract in accordance with the bid, plans, detailed specifications and
bills of material; and in the event the Principal pays to the Oblige the difference not to
exceed ten percent (10%) of the penalty hereof between the amount specified in the bid
and such larger amount for which the Oblige may in good faith contract with the next
lowest bidder to perform the work covered by the bid; or in the event the Oblige does
not award the contract to the next lowest bidder and resubmits the project for bidding,
the Principal pays to the Oblige the difference not to exceed ten percent (10%) of the
penalty hereof between the amount specified in the bid, or the costs in connecting with
the resubmission, of printing new contract documents, required advertising, and printing
and mailing notices to prospective bidders, whichever is less, then this obligation shall
be null and void, otherwise to remain in full force and effect; if the Oblige accepts the
bid of the Principal and the Principal within ten (10) days after the awarding of the
contract enters into a proper contract in accordance with the bid, plans, details,
specifications and bills of material, which said contract is made a part of this bond the
same as though set forth herein.

Now also, if the said Principal shall well and faithfully do and perform the things agreed
to be done and performed according to the terms of said contract; and shall pay all
lawful claims of subcontractors, material men, and laborers, for labor performed and
material furnished in the carrying forward, performing or completing of said contract; we
agreeing and assenting that this undertaking shall be for the benefit of any material man
or laborer having a just claim, as well as for the Oblige herein; then this obligation shall

be void; expressly understood and agreed that the liability of the surety for any and all claims hereunder shall in no event exceed the penal amount of this obligation as herein stated.

The above Surety hereby certifies that it is authorized by the superintendent of insurance, State of Ohio, to execute the above bond and that the liability incurred is within the limits prescribed by Section 3929.121 of the Ohio Revised Code.

The said Surety hereby stipulates and agrees that no modifications, omissions or additions in or to the terms of the said contract or in or to the plans or specifications therefore shall in any way affect the obligation of said surety on its bond and does hereby waive notice of any such modifications, omissions or additions to the terms of the contract or in or to the plans and specifications.

SIGNED AND SEALED this _____ day of _____, 20____.

Principal:

Signature

Printed Name: _____

Title: _____

Surety:

Surety Company:

Name: _____

Address: _____

By: _____
Attorney-in-fact

Surety Agent:

Name: _____

Address: _____

VII. PROPOSAL

Ottawa, Ohio, _____, 20_____

To the Board of County Commissioners:

The undersigned Bidder certifies the pre-bid examination, in its entirety, of all Bid Documents contained in or referenced by this Proposal, including the Notice to Bidders, Instructions to Bidders, General & Supplemental Provisions, Standard Specifications, Scope of Work, Plans & Specifications, and Planned Bid Items & Quantities, which shall govern this improvement and are made a part of this Proposal and the ensuing contract.

DESCRIPTION OF THE IMPROVEMENT

Road 19—RCB & Wingwalls

The undersigned Bidder proposes to furnish any and all material, tools, labor, transportation, machinery, appliances, and appurtenances necessary, and to prosecute to full completion, the Work called for hereunder, and in consideration thereof, to accept from the County, as full payment for completion of each item as specified, the respective unit or lump sum price hereafter set forth.

The undersigned Bidder agrees that, if this Proposal is accepted, said Bidder will, within ten (10) days after notification of such acceptance, enter into the contract for the performance of the Work proposed and, as a guarantee of the faithful performance thereof, to furnish at the time of executing the contract, a bond in the amount equal to 100% of the total Bid price, with a Surety subject to the approval of the County.

Bidder hereby agrees to commence work under this contract on or before a date to be specified in the Notice to Proceed and to fully complete the Project by: **July 31, 2024**. Bidder further agrees to pay as liquidated damages, per ODOT Item 108.07, ODOT specifications latest editions and as provided in Section II. (7) of these documents.

The Bidder hereby agrees that the Board of County Commissioners has the right to reject any and all bids, and the Bidder will not dispute the correctness of the quantities used to determine the lowest and best bid.

Accompanying this Bid is a bid guarantee or bond payable to the County. Upon any failure to execute the Contract or provide an adequate performance bond as aforesaid, it is agreed that the undersigned Bidder shall forfeit the bid guarantee or bond accompanying the proposal to the County, to the extent allowed by law.

Bidder acknowledges receipt of the following addendum:

Bidder (full name): _____

Signed: _____

Printed Name: _____

Title: _____

Bidder's mailing address: _____

Phone Number: _____

Fax Number: _____

- Attch: Bid Guarantee or Bond
- Bid Prices (completed unit & lump sum price list)
- Supplemental Bidder Qualification Forms (if any)
- Equal Opportunity Compliance Certificate
- Declaration: Personal Property Tax Delinquency
- Certificate: Unresolved Findings of Recovery
- Release of Liens

BID PRICES
Planned Bid Items & Quantities

Furnish & Deliver RCB & Wingwalls

Engineer's Estimate:
\$125,000.00

				UNIT COST	TOTAL COST
ITEM	DESCRIPTION	QTY.	UNIT		
<i>Road 19 Culvert Replacement</i>					
611 Special	Furnish and deliver a 5'x14' Reinforced Concrete Box	88	LF		
611 Special	Furnish and deliver precast full-height L-shaped wingwalls at a length of 14 feet. (7' height x 14' length x 1' thick) (SEE ATTACHED drawing for wingwall angles)	4	EACH		
TOTAL					

Notes:

- Reinforced precast concrete shall have a compressive strength of 5,000 psi at 28 days.
- Plain wire mesh reinforcing in box culvert shall have a minimum yield strength of 65,000 psi and conform to ASTM A1064.
- Epoxy reinforcing bars shall have a minimum yield strength of 60,000 psi and conform to ASTM A615.
- Culvert sections designed per ASTM C-1577, HL-93 Loading with 0' to 2' earth cover.
- Total bid price includes manufacturing the RCB, wingwalls, and delivery.
- The RCB manufacturer must supply the County with the shop drawings, HL-93 Load Rating report and computer file needed for the AASHTO BrR software.
- County will pour footers for each end of the RCB and also for each wingwall before delivery.
- The RCB manufacturer must supply the County the epoxy-coated hook bars needed to reinforce the L-shaped wingwalls to the poured footers.
- The County Engineer must approve the shop drawing before fabrication.

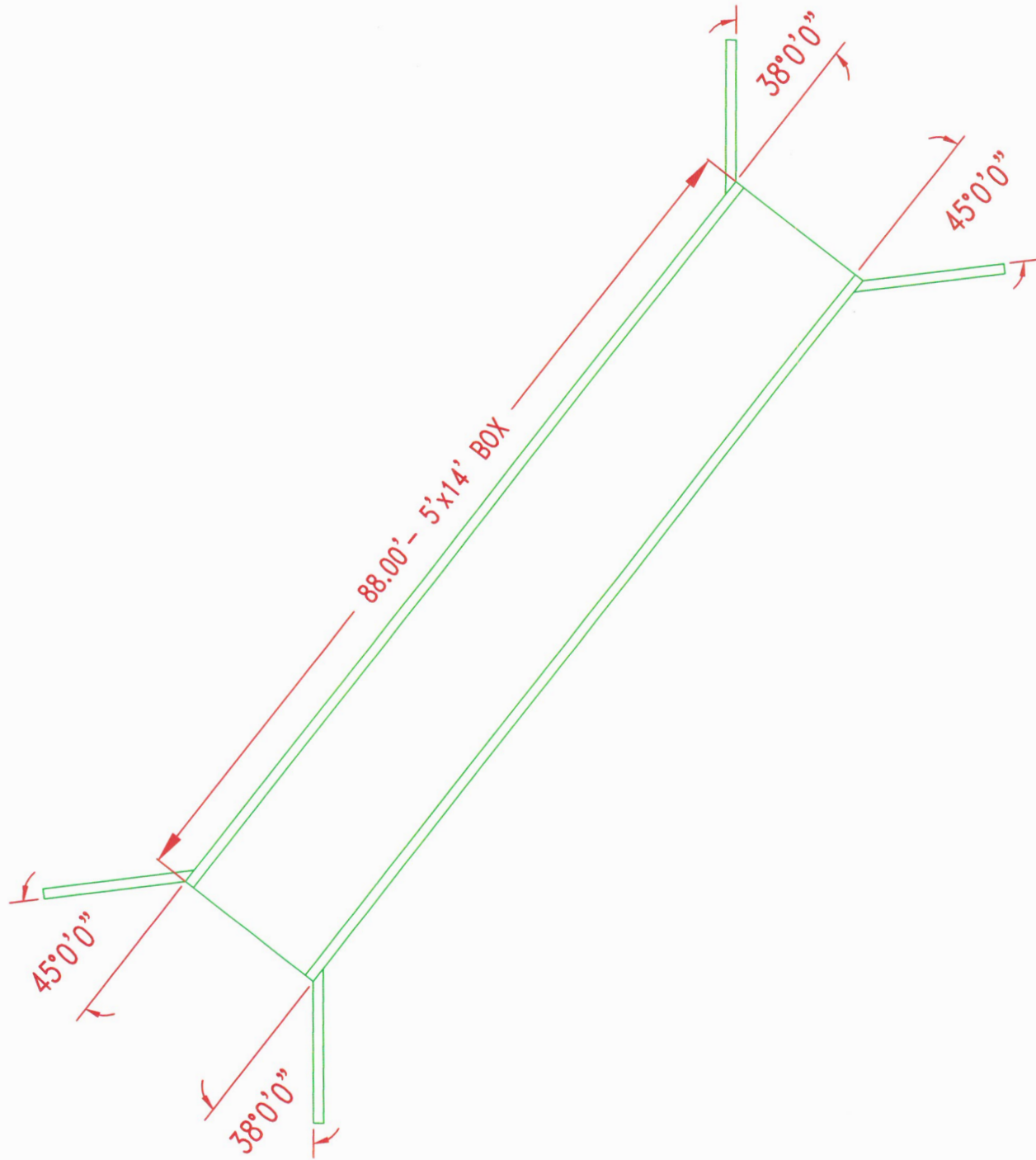

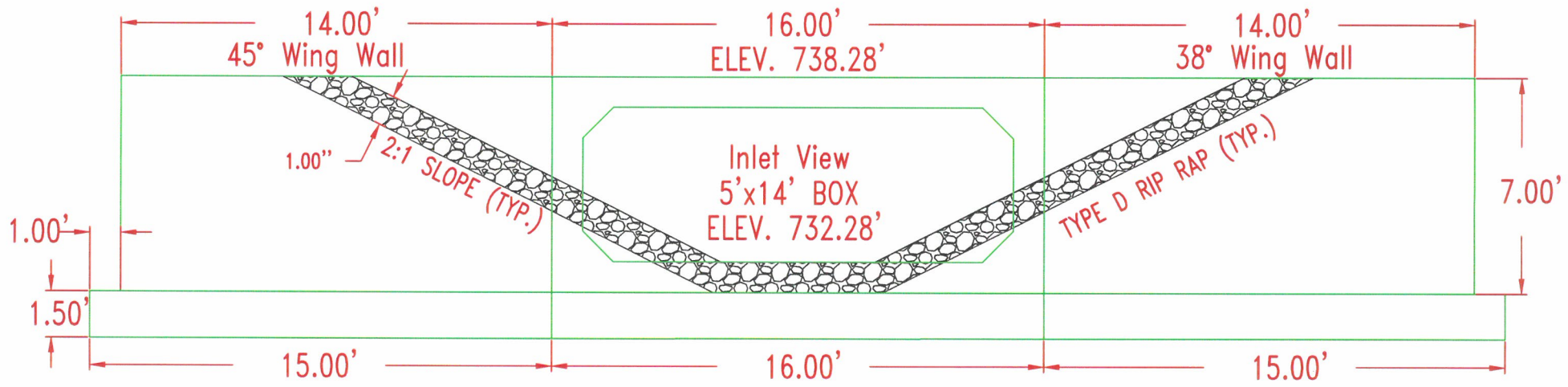

VIII. ARTICLES OF AGREEMENT

This Agreement is made and entered into by the County, acting by and through its Board of County Commissioners, and the Contractor identified below, hereinafter called the Contractor.

WITNESSETH:

The Contractor, for and in consideration of certain payments to be made as specified herein, hereby covenants and agrees to perform and execute all provisions of its Proposal for construction of the subject public improvement, including fulfillment of the requirements of the Notice to Bidders, Instructions to Bidders, General & Supplemental Provisions, Standard Specifications, Scope of Work, Plans & Specifications, and Planned Bid Items & Quantities, and to be governed by the provisions contained therein, setting forth duties, relations and obligations of the Engineer, Contractor and the Surety, which are hereto attached and made a part hereof, and agrees to fully and completely perform the Work described hereby in a manner to achieve completion thereof by or before the completion date of: **July 31, 2024.**

In consideration of the performance by the Contractor of the covenants and agreements as herein set forth, the County hereby covenants and agrees to pay the Contractor according to the schedule of rates and prices set forth in the attached Proposal of said Contractor, and at the time and in the manner hereinafter set forth herein.

IN WITNESS WHEREOF, the parties to this Agreement have hereunto set their hands effective this _____ day of _____, 20_____.

COUNTY OF PUTNAM

CONTRACTOR (full name)

(Signature)
Board of Commissioners

(Signature)
Contractor

(Printed Name & Title)

(Printed Name & Title)

(Mailing Address)

Approved on County's behalf as to form:

By: _____
For: Prosecuting Attorney

Date: _____

COUNTY AUDITOR'S CERTIFICATE

CONTRACT NO: _____ PROJECT: _____
FUND: _____ VENDOR NO: _____
DATE: _____ VENDOR: _____

It is hereby certified that the amount to meet the obligation of this contract in the fiscal year in which the contract has been made has been lawfully appropriated for the purposes of the contract and is in the Putnam County Treasury of in the process of collection to the credit of the _____ Fund free from any previous encumbrances, obligations or certificates now outstanding.

Putnam County Auditor

It is hereby certified that the amount (\$ _____) required to meet the contract, agreement, obligation, payment or expenditure for the above, has been lawfully appropriated or authorized or directed for such purpose and is in the Putnam County Treasury or in the process of collection to the credit of the _____ Fund free from any obligation or certification now outstanding.

Putnam County Auditor

It is hereby certified that the amount (\$ _____), for the fiscal year _____ required to meet the contract, agreement, obligation, payment or expenditure, for the above, has been lawfully appropriated or authorized or directed for such purpose and is in the Putnam County Treasury or in the process of collection to the credit of the _____ Fund free from any obligation or certification now outstanding. Outstanding balance of contract, estimated (\$ _____) to be appropriated for the fiscal year(s) _____.

Putnam County Auditor

**THIS CONTRACT IS NOT VALID UNLESS COUNTY AUDITOR'S CERTIFICATE
IS SIGNED**